

THIS DRAWING IS UNPUBLISHED. RELEASED FOR PUBLICATION, 19  
 © COPYRIGHT 19 BY AMP INCORPORATED. ALL INTERNATIONAL RIGHTS RESERVED.

LOC	DIST	P	F	REVISIONS				
				ZONE	LTR	DESCRIPTION	DATE	APPD
AF	50				C1	REV PER ECR 06-028943	13DEC06	JR/PD

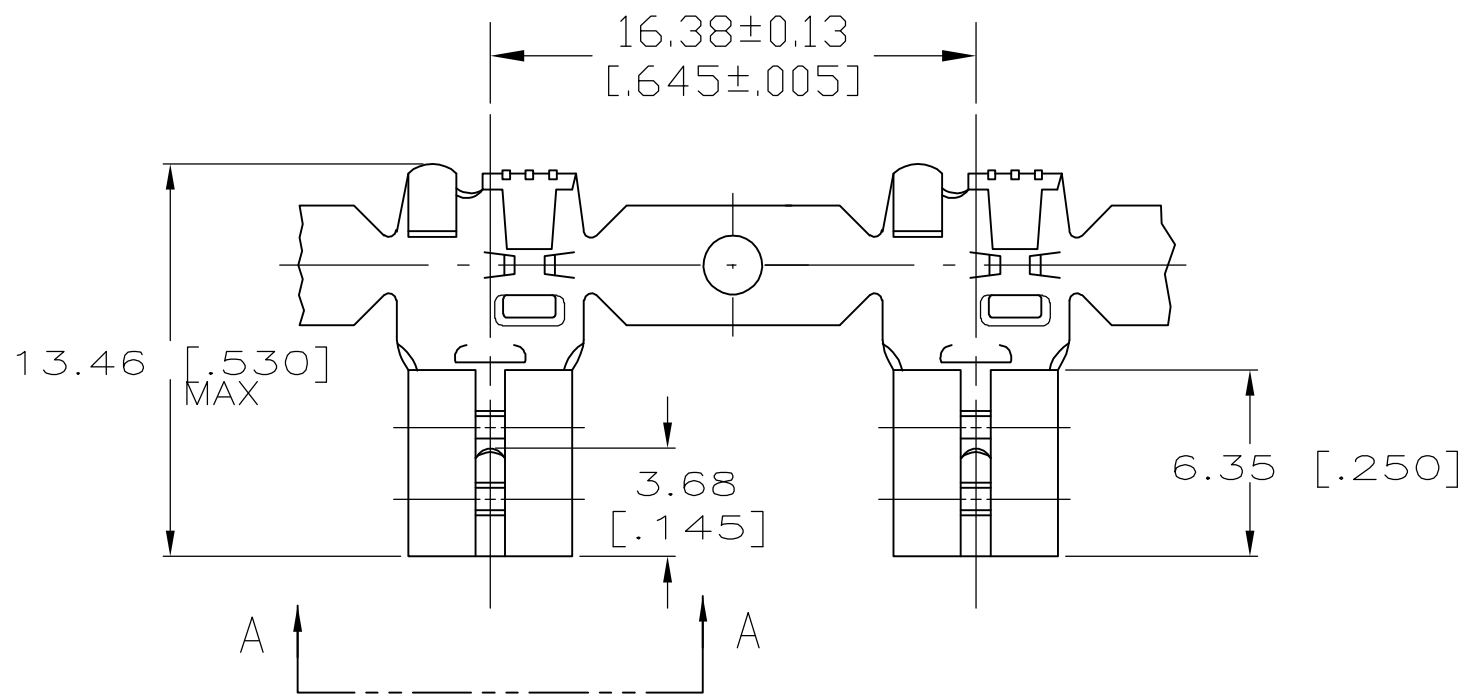

1 CONTINUOUS STRIP ON REELS.

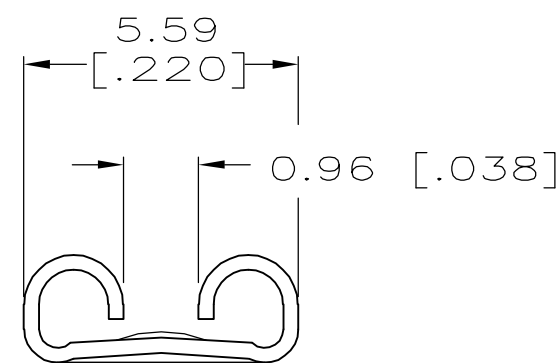

VIEW A-A

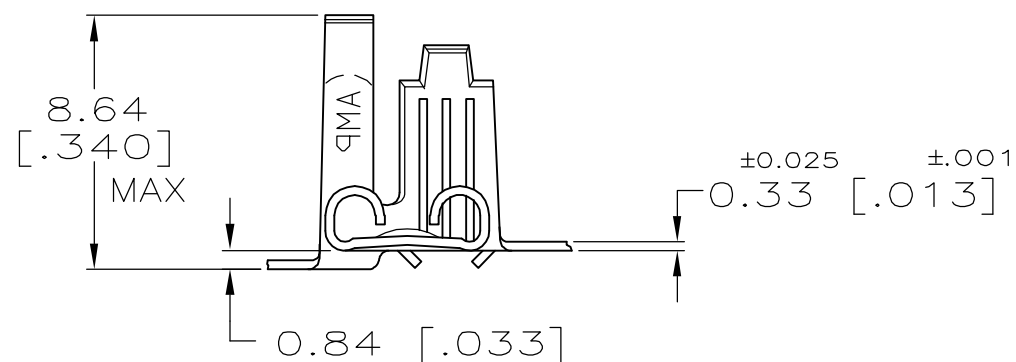

THIS DRAWING IS A CONTROLLED DOCUMENT FOR AMP INCORPORATED. IT IS SUBJECT TO CHANGE AND THE CONTROLLING ENGINEERING ORGANIZATION SHOULD BE CONTACTED FOR THE LATEST REVISION.

2.79-4.32 DIA [.110-170] DIA	#20-#16 AWG	0.81 [.032]	63696-1
INSULATION RANGE	WIRE SIZE	MATING TAB THK ±0.025 [.001]	PART NO
DO NOT SCALE PRINT. UNLESS SPECIFIED DIMENSIONS IN mm [INCHES] TOLERANCES ON: 2 PLC DEC ± 0.25 [.010] 3 PLC DEC ± - ANGLES ± -	DR 6/2/93 JR RUTH CHK 6/2/93 MS FEHER APPD 6/2/93 P DESANTIS APPD 6/2/93 R REINER PRODUCT SPEC -	AMP AMP Incorporated Harrisburg, PA 17105-3608	
MATERIAL T2 STEEL	FINISH NICKEL 0.00381 [.000150] MIN	NAME RECEPTACLE, FASTON, FLAG, 4.75 [.187] SERIES	
	APPLICATION SPEC 114-2078	SIZE B	CAGE CODE 00779
	WEIGHT -	DRAWING NO C-63696	SHEET 1 OF 1
		SCALE 4:1	